

DOI: <https://doi.org/10.63359/n48a6j80>

Maximization of Operating Pressure and Activation Overpotential on Green Hydrogen Gas Purity of Alkaline Water Electrolysis Plants Simulated

Awad Alshebani^{1*} Marwa Salem² Hamid Younis Ahmed³

ARTICLE INFO

Vol. 8 No. 1 April, 2026

Pages (132- 139)

Article history:

Revised form 30 March 2026

Accepted 21 April 2026

Authors affiliation

¹Chemical Engineering department,
Faculty of Engineering Sirte University
che.eng@su.edu.ly

²Chemical Engineering department,
Faculty of Engineering Bright star
University-Brega
mrwtalmshyty@gmail.com

³Chemistry department, Faculty of science,
Sirte University
hamid.younis@su.edu.ly

Keywords:

Green hydrogen, Alkaline water electrolysis, Operating pressure, Activation overpotential, Gas purity, Aspen Plus simulation, KOH electrolyte, Energy efficiency.

© 2026

Content on this article is an open access licensed under creative commons CC BY-NC 4.0.



ABSTRACT

The production of green hydrogen through the alkaline water electrolysis (AWE) can generate a sustainable source of energy and decarbonization solution that will be further improved by the use of renewable energy sources. The paper tends to investigate the way the operating factors (pressure, temperature and concentration of electrolytes (KOH and NaOH) Besides the applied current and voltage effect on the hydrogen production in addition to energy consumption and purity of produced gas. Experiments were conducted in the laboratory with a custom electrolysis cell that held stainless steel electrodes and a variety of concentrations of KOH and NaOH to demonstrate that the KOH provides better results to the NaOH because of the greater currents (up to 6 A) and voltages (up to 40 V) produced which lead to larger amounts of H₂ (1 It was found that the optimum performance is achieved in a system at high temperatures of feed 90°C and medium pressure of approximately 12 bar where KOH concentrations of 20-25 wt% increase optimal system performance. Systems based on KOH had a maximum electrolyser efficiency of about 65 percent and the reference system had a maximum electrolyser efficiency of about 60 % and a power consumption of about 39.5 kW per kilogram of H₂ generated. The results of the research which we reference point towards the fact that AWE design will be simplified in such a way that it could produce the production system which would be operational at the low levels of carbon emissions and generate the hydrogen which could be utilized in the petrochemical and renewable energy activity.

محاكاة تأثير ضغط التشغيل وفرط جهد التنشيط على نقاء غاز الهيدروجين الأخضر والكفاءة الإجمالية لمحطات التحليل الكهربائي للماء القلوي

عوض الشيباني مروة سالم احمد يونس احمد

يمكن لإنتاج الهيدروجين الأخضر من خلال التحليل الكهربائي للماء القلوي أن يُؤدّد مصدرًا مستدامًا للطاقة وحلًا لإزالة الكربون، وهو ما سيتحسن أكثر باستخدام مصادر الطاقة المتجددة. تحدف هذه الورقة البحثية إلى دراسة كيفية تأثير عوامل التشغيل (الضغط، ودرجة الحرارة، تركيز الإلكتروليتات (هيدروكسيد البوتاسيوم وهيدروكسيد الصوديوم)، بالإضافة إلى التيار والجهد المطبقين، على إنتاج الهيدروجين، كذلك استهلاك الطاقة، ونقاء الغازات المنتجة. أُجريت التجارب العملية باستخدام خلية تحليل كهربائي مصممة خصيصًا، تحتوي على أقطاب كهربائية من الفولاذ المقاوم للصدأ، بتراكيز مختلفة من هيدروكسيد البوتاسيوم KOH وهيدروكسيد الصوديوم NaOH، لإثبات أن هيدروكسيد البوتاسيوم يعطي نتائج أفضل من هيدروكسيد الصوديوم نظرًا لزيادة التيار (حتى 6 أمبير) والجهد (حتى 40 فولت)، مما يؤدي إلى كميات أكبر من الهيدروجين المنتج H₂. وجد أن الأداء الأمثل يتحقق في نظام يعمل عند درجة حرارة تغذية عالية (90 م°) وضغط متوسط يبلغ حوالي 12 بار، حيث تحسن تراكيز هيدروكسيد البوتاسيوم التي تتراوح بين 20-25% وزنيًا من أداء النظام. بلغت كفاءة التحليل الكهربائي القصوى للأنظمة القائمة على هيدروكسيد البوتاسيوم حوالي 65%، بينما بلغت كفاءة التحليل الكهربائي القصوى للنظام المرجعي حوالي 60%، مع استهلاك طاقة يبلغ حوالي 39.5 كيلوواط لكل كيلوغرام من الهيدروجين المنتج. تشير نتائج البحث الذي نستشهد به إلى إمكانية تبسيط تصميم محطات التحليل الكهربائي المائية (AWE) بحيث تنتج نظامًا يعمل بمستويات منخفضة من انبعاثات الكربون، وينتج الهيدروجين الذي يمكن استخدامه في أنشطة البتروكيماويات والطاقة المتجددة.

INTRODUCTION

The energy management programs are currently centred on the issue of sustainable sources of energy in order to minimize damage to the environment and still not diminish future energy requirements. The global energy is still dependent on the old fossil fuels containing coal and oil and natural gas. The report of the International Energy Agency IEA of 2024 states that the world is shifting towards renewable energy that includes energy sources like solar energy and wind energy and hydro electric energy and geothermal power plants. The evolution of hydrogen has enabled it to be a diversified source of energy that can be utilized in any energy need according to the fact that hydrogen is efficient in generating high energy output because it generates clean combustion (Encyclopaedia Britannica n.d.; U.S. Department of Energy n.d.). One of the most significant methods of hydrogen production is electrolysis as it is based on the use of electric current as a method of separating water into hydrogen and oxygen relying on the proven technology. Through the process, organizations are able to create high quality hydrogen through the assistance of hydrogen manufacturing by using environmental energy sources U.S. Department of Energy n.d.; National Renewable Energy Laboratory n.d. The following are the objectives of the study; to streamline the electrolysis process by experimenting with the different parameters of voltage and current density and the kind of electrolytes used and to research on the performance of alkaline and acidic electrolytes of the solution and also to conduct experimental tests to obtain a data of hydrogen production and energy efficiency of output of the solution in various operating conditions. The study aims at establishing hydrogen generation techniques that are going to sustain utilization of environmentally sustainable energy systems as stated by the U.S Department of Energy and National Renewable Energy Laboratory.

The global warming of the climate due to man such as burning fossil fuels whereby greenhouse gases are released to the atmosphere is also the climate issue. These gases trap the heat in the atmosphere, thus the increase in heat on earth, green hydrogen is a clean source of energy that would never lead to the emission of greenhouse gases during production or consumption. The process of creating green hydrogen is done by means of electrolysis whereby electricity is utilized to separate the water into hydrogen and oxygen. As the electricity which is utilized in the electrolysis process is of renewable origin, say a solar or wind energy, then the hydrogen being generated will be a wholly clean fuel. The connection between the climate issue and green hydrogen is that the hydrogen can be a viable option to minimize the greenhouse gas emissions and fight against the issue of climate change. Green hydrogen can be applied in different ways The deployment of green hydrogen could help in changing the world

economy to a low-carbon economy, which will help in mitigating the effects of the climate change.

MATERIALS AND METHODS

The section presents a detail of the materials, experiment set up and the research methods employed in the study of hydrogen production through electrolysis of water. The paper has assessed the efficiency of the production of hydrogen under the varying operating conditions by experimenting on different current and voltage and concentration of electrolytes and reaction time parameters. The tests were carried out in the laboratory conditions with the alkaline electrolytes that comprised potassium hydroxide (KOH) and sodium hydroxide (NaOH), commonly used in the alkaline water electrolysis systems due to their high ionic conductivity and stability of operation (National Renewable Energy Laboratory [NREL], 2024; U.S. Department of Energy [DOE],

Materials

Electrolysis experiments have been conducted with the help of different laboratory materials and equipment. The primary choice made by the researchers was to use distilled water as the primary solvent due to its high purity level that would avoid impurities interfering with the electrochemical reactions that would give false experimental results (Abdel Rahman, 2008; Gad, 2009). Due to the fact that sodium hydroxide (NaOH) and potassium hydroxide (KOH) offer high ionic conductivity that is frequently used by the industrial facilities in terms of their alkaline electrolysis systems, alkaline water electrolysis systems run with these compounds as electrolytes (Dubouis and Grimaud, 2024; Kumar et al., 2022).

Their electrode material was stainless steel 316, due to its excellent corrosion protection and high mechanical strength and supports hydrogen evolution reaction which takes place under alkaline environment (Lavorante et al., 2016; Olivares-Ramírez et al., 2007). Electrolysis cell joins the cathode and anode to the power supply using electrical wires. The laboratory members utilized glass beakers and conical flasks and graduated cylinders and stirring rods and plastic containers to prepare the electrolyte solutions and know the volume of hydrogen produced.

The resulting distillation water that was obtained was of high purity, and the constant conductivity environment was achieved through the employment of distillation equipment used to acquire the demanded distilled water to prepare solutions of electrolytes. The distillation apparatus comprised of in the experiments is depicted in Figure 1.



Figure (1): Distillation device

The electrodes used in the electrolysis cell were also made of stainless steel and this is shown in Figure 2.

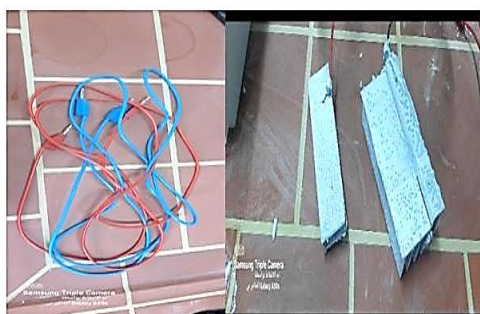

Figure (2): Electrode materials stainless steel 316

Besides, other related electrical equipment is also present in the experiment set-up as it is illustrated in Figure 3 shows Electrical devices used and laboratory containers and glass equipment.



Figure (3): Electrical devices used

Experimental Setup

The experimental equipment was a cell of electrolysis which was connected to a variable DC power supply. The applied voltage and current that was needed in the electrolysis process were controlled with the power supply. These experiments dealt with electrical parameters and to measure it, electrical measuring devices (ammeter and digital multimeter) were watched.

The electrolysis cell was used as testing equipments when the stainless-steel electrodes of the electrolysis cell were immersed into the electrolyte solution that had KOH and NaOH dissolved in distilled water. Electrochemical reaction began as direct electric current was passed through the electrodes that led to a break in the molecules of water into hydrogen gas in the cathode and oxygen gas in the anode (U.S. Department of Energy [DOE], n.d.; National Renewable Energy Laboratory [NREL], 2004). The electrolyte solutions of concentration in the test solutions were the problem solutions to the experiment. The ready electrolysis solution of both KOH and NaOH are presented in Figure 4. KOH and NaOH solutions were used as electrolysis media.



Figure (4): Electrolysis media for KOH and NaOH

The entire system of electrolysis applied in the production of hydrogen is available in Figure 5. Experimental set up for H₂ production using electrolysis cell, and demonstrates the layout of the power supply, electrodes and the location of the electrolyte.



Figure (5): Electrolysis media for KOH and NaOH Simulation Model

Aspen Plus model simulated an AWE plant by thermodynamic equilibrium and mathematical equations that were represented in Figure 6. The experiment held some parameters of cell design in which KOH/NaOH electrolytes were run at 40°C under different pressure conditions. Errors with literature to obtain measurements of power (kW/kg H₂) as well as efficiency (3: etc. = 65 percent) remained under 6 percent in the validation process.

Table (1): KOH model results validation with reference.

Parameters	KOH Model result	Value Ref.	Error
Power per KW/kgH ₂	39.5222532	42	5.9%
Water conversion % (faradic efficiency)	97.5%	99.7%	2.3%
Temperature °C	40.0	40.0	0.0%
Performances of an electrolyzer %	65%	60%	7.7%

Table (2): NaOH model results validation with reference.

Parameters	NaOH Model result	Value Ref.	Error
Power per KW/kg H ₂	39.5686465	42	5.8%
Water conversion % (faradic efficiency)	97.5%	99.7%	2.3%
Temperature °C	40.0	40.0	0.0%
Performances of an electrolyzer %	65%	60%	7.7%

Preparation of Electrolyte Solutions.

Dissolution of the measured quantities of potassium hydroxide (KOH) and sodium hydroxide (NaOH) dissolution in distilled water produced electrolytes. The right salinity of the solution was prepared by weighing the electrolyte salts in masses in an electronic balance with a weighing capacity of 200g of the electrolyte.

To investigate the effect of concentration on the production of hydrogen, four concentrations of each type of the electrolyte solutions were made. The concentrations under test were:

- 10 g/L
- 15 g/L
- 20 g/L
- 25 g/L

The ready solutions were stirred to produce homogeneous distributions of the electrolyte in water and then the solutions were added to the electrolysis cell.

Measurement of Hydrogen Gas

The displacement of water was obtained to measure the generated amount of hydrogen gas during the electrolysis process. The hydrogen generated at the cathode was gathered in an inverted graduated cylinder in a water bath in this method. Because Hydrogen gas accumulated in the cylinder; it made the equal season of volume of water to move out of the cylinder and the volume of hydrogen generation could be determined.

The method is commonly used in conducting electrolysis because Hydrogen is a gas which is not colored or smelly and therefore, it is difficult to quantify. The displacement of the amount of water may serve as a good measure of the speed at which the hydrogen is generated during the electrolysis process.

Solution Properties Measurement.

To identify the properties of the electrolyte solutions that were used in the experiments, pH and electrical conductivity measurements were conducted.

PH meter was utilized to sample PH in KOH and NaOH solutions to understand the extent of alkalinity of the two

solutions. Another factor that leads to the efficiency of the electrochemical process occurring in the electrolysis of water is the electrolyte alkalinity.

The conductivity was checked with the help of a conductivity meter which included a probe that was inserted into the solution of the electrolyte. The values of conductivity were in microsiemens/centimeter (µS/cm). Their conductivity is high and this enhances the flow of ions in the electrolyte and this intensifies the production of hydrogen.

Operating Parameters Categorized.

The experiments aimed at examining the impact of various operating parameters on the efficiency of hydrogen production. The essential parameters to be experimented on were, applied current, applied voltage, electrolytic time and electrolyte concentration.

A current was changed between 1 A and 6 A to determine its effect in the hydrogen production rate. In general, an increment in current results in an increment in rate of hydrogen generation since it results in faster electrochemical reaction rates. This was also varied in applied voltage which was taken to be 15 V and 40 V to determine the impact of the same on the electrolysis process. Hiking up of the degree of voltage has the potential to boost production of hydrogen but may also boost energy consumption. Another parameter of the experiments was electrolysis time. Measures of Hydrogen production were made at various time intervals between 2 and 7 minutes so as to ascertain how the electrode remained stable as well as the rate of hydrogen production in time.

The analysis was performed through an examination of the effect of the KOH and NaOH concentrations on the output of their experiments. Alteration of ionic conductivity caused by the changes in the concentration of electrolytes in turn causes changes in reaction rates of electrochemical reactions that define the effectiveness of a hydrogen generation by alkaline water electrolysis systems (International Energy Agency [IEA], 2022; U.S. Department of Energy [DOE], n.d.; National Renewable Energy Laboratory [NREL], 2024).

Researchers built a unique electrolysis cell which used glass together with stainless steel 316 electrodes as its main materials. The authors prepared all the electrolyte solutions using distilled water since they did not want to include impurities that would interfere with the electrochemical reactions. Two alkaline solutions that were experimented on by the researchers were NaOH and KOH that had five different concentrations (5, 10, 15, 20, and 25 g/L).

The electrodes were attached to the variable DC power supply enabling them to administer current between 1 A to 6 A and voltage between 15 V and 40 V. All laboratory experiments were done by the researchers at room temperature between 25 °C and 27 °C and at 1 bar of atmospheric pressure. To determine the volume of hydrogen gas by the water displacement technique, the researchers applied the method of determining the volume of the hydrogen gas using an inverted graduated cylinder which they immersed in a water bath. The researchers

measured electrical conductivity and pH of all solutions (electrolytes) using calibrated meters before and after each experiment. The scientists did three experiments on each of the experimental conditions to confirm their findings. The researchers varied the electrolysis time to 2 to 7 minutes.c

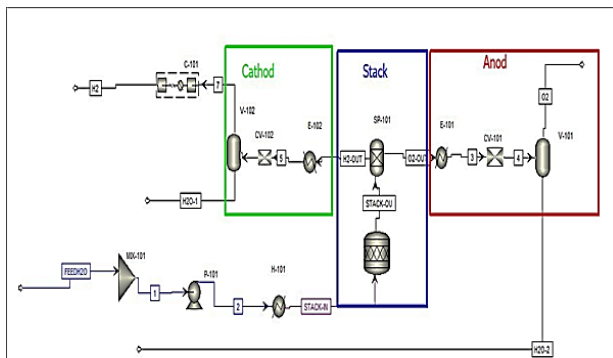

Figure (6): Process flow sheet of alkaline electrolytes membrane plant to production of hydrogen.

Process flow diagram explains the way the alkaline water electrolysis plant runs based on its Aspen Plus simulation. The flow diagram depicts the prime areas of the system such as the cathode compartment (green) the electrolysis stack (blue) and the anode compartment (red). This system delivers water into the system by pumping and it is mixed with reused electrolyte and put into the electrolysis stack. Hydrogen is generated at the cathode side and oxygen at the anode side. The simulation entails gas-liquid separation separators and gas cooling systems, and waste material return systems which maintain the electrolyte levels and increase the overall working performance.

Table (3): The result of simulation KOH model in aspen plus.

items	Value	Units	Value	Units
KOH feed	1.00	kmol/hr	20.00	kg/hr
H ₂ O Feed	55.51	kmol/hr	1000.00	kg/hr
H ₂ product	54.60	kmol/hr	113.23	kg/hr
O ₂ product	27.32	kmol/hr	872.60	kg/hr
Power required	4334.28	KW		
Power per Kmol H ₂	79.3880302	KW/Kmol H ₂		
H ₂ product	1352.00522	m ³ /hr at 1 bar and 25 °C		
Power per m ³ H ₂	3.20581838	KW/m ³ H ₂		
Power per Kg H ₂	38.2799675	KW/Kg H ₂		

The table above presents the detailed material and energy balance results for the alkaline water electrolysis plant using KOH as the electrolyte. The simulation was performed with a feed of 1.00 kmol/hr (20 kg/hr) of KOH and 55.51 kmol/hr (1000 kg/hr) of water. The process produced 54.60 kmol/hr (113.23 kg/hr) of hydrogen and 27.32 kmol/hr (872.60 kg/hr) of oxygen. The electrolyzer needed 4334.28 kW of total power which resulted in specific energy usage rates of 79.39 kW/kmol H₂ 3.21 kW/m³ H₂ and 38.28 kW/kg H₂. The volumetric flow rate of hydrogen produced was 1352.01 m³/hr at standard

conditions (1 bar and 25°C). The results show how efficient KOH-based systems perform when they operate under simulated test conditions.

Table (4): The result of simulation NaOH model in aspen plus.

items	value	Units	Value	Units
NaOH feed	1.00	kmol/hr	20.00	kg/hr
H ₂ O Feed	55.51	kmol/hr	1000.00	kg/hr
H ₂ product	54.53	kmol/hr	113.31	kg/hr
O ₂ product	27.32	kmol/hr	871.34	kg/hr
Power required	4333.61	KW		
Power per Kmol H ₂	79.46979043	KW/Kmol H ₂		
H ₂ product	1348.189928	m ³ /hr at 1 bar and 25 °C		
Power per m ³ H ₂	3.214387951	KW/m ³ H ₂		
Power per Kg H ₂	38.24522685	KW/KgH ₂		

The table gives the specific results of material and energy balance of the alkaline water electrolysis plant with KOH as the electrolyte. The feed used in carrying out the simulation was KOH 1.00 kmol/hr (20 kg/hr) and water 55.51 kmol/hr (1000 kg/hr). The process produced 54.60 kmol/hr (113.23 kg/hr) of hydrogen and 27.32 kmol/hr (872.60 kg/hr) of oxygen. The total power of the electrolyzer was 4334.28 kW that translated to 79.39 kW/kmol H₂ 3.21 kW/m³ H₂ and 38.28 kW/kg H₂. At standard conditions (1 bar and 25 °C), the volumetric flow rate of hydrogen produced was 1352.01 m³/hr. The results reveal the level of efficiency of KOH-based systems on simulated test conditions.

RESULTS AND DISCUSSION

Results

The section contains the experimental findings and the simulation findings that were derived through hydrogen production experiment and Aspen Plus model. The data show the influence of the basic operational parameters that comprise applied current and voltage and the concentration and temperature and pressure of electrolytes on the hydrogen production and the performance of the system. The researchers examined the experimental findings and also the simulation findings in order to research on the electrolysis process and to find the optimal operating parameters.

Experimental Results

The researchers experimented with different operating conditions such as the current setting, voltage and duration of electrolysis and the concentration of electrolytes to establish how they affect hydrogen production. Two alkaline electrolytes were used in the experiments, namely potassium hydroxide (KOH) and sodium hydroxide (NaOH) since the substances are the main electrolytes to be used in the electrolysis of alkaline water as they are

capable of conducting electricity and remain stable in alkaline conditions (National Renewable Energy Laboratory [NREL], 2024; U.S.

The outcome of the experiment indicated that the effect it had on hydrogen production increased the more current and voltage was used. Increase in electrical input is known to speed up the rate of rate of electrochemical reactions occurring at the electrode surfaces and result in increasing the rate of decomposition of water into hydrogen and oxygen. However, it was also found that the kind of electrolyte plays some role too in determining the production efficiency of hydrogen.

The Figure below 7 Effective of Applied Time vs Applied Current demonstrates the effect of applied time as opposed to applied current at a constant voltage of 15 V at an applied concentration of 5 g /inter concentration of NaOH in water. The figure proves that rate of hydrogen production increases almost proportionately with time and current. However, ionic conductivity is also limited by the comparatively low concentration of electrolytes, hence the volumes of hydrogen go smaller than in the case of high concentration of electrolytes.

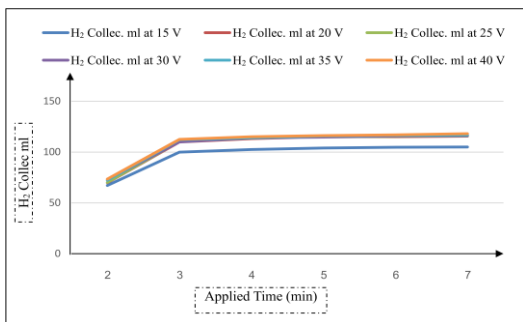

Figure (7): Effective of Applied Time vs Applied Current with electrolyte concentration is 5 g NaOH/liter water and Constant voltage 15 V.

Further experiments carried out on solutions of NaOH at elevated concentrations Figure 8 indicated that an increased current leads to increased production of hydrogen that begins to level off with increase in electrolyte concentration above approximately 15 g/L. This trend means that NaOH solutions are saturated such that further increase in electrolyte concentration does not considerably promote the generation of hydrogen.

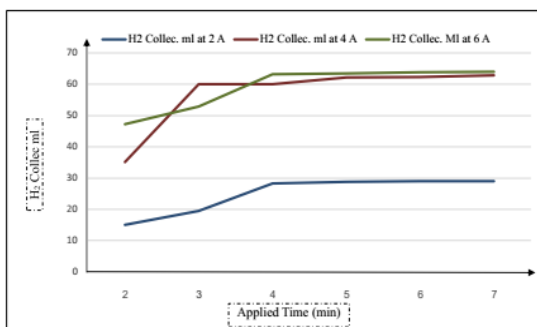

Figure (8): Effective of Applied Time vs Applied Current with electrolyte concentration is 10 g NaOH/liter water and Constant voltage 15 V.

On the other hand, the one, which utilized potassium hydroxide as electrolytes, was more effective in hydrogen production. The dependence between Applied time and current at 15 g KOH/L electrolyte concentration at the constant voltage of 15 V is shown in Figure 9. Effective Applied Time vs Applied Current with electrolyte content of water is 15 g KOH/liter water and Constant voltage 15 V. The findings demonstrate that there is a substantial growth in the hydrogen production at all the current levels applied. The highest amount of hydrogen was approximately 145.15 mL and this was a very large amount, when compared with the amounts that were recorded as a result of using NaOH when operating under the same conditions.

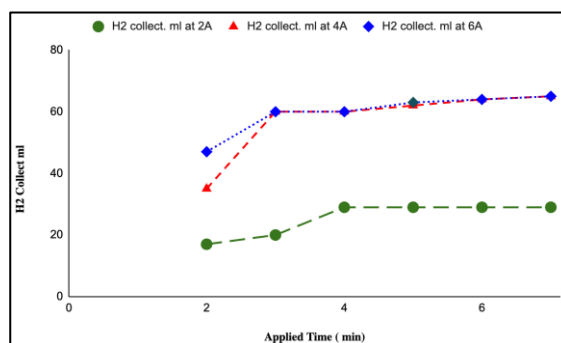

Figure (9): Effective of Applied Time vs Applied Current with electrolyte concentration is 15 g KOH/liter water and Constant voltage 15 V.

These results indicate that KOH electrolytes have better conductivity and reduced resistivity, thereby promoting ions flow more easily and reaction of hydrogen evolutions faster. Therefore, KOH electrolytes show an improved electrochemical performance as compared to the NaOH electrolytes in alkaline electrolysis reactions.

Simulation and Sensitivity Analysis

Besides the experimental study, simulation analysis was done by applying Aspen Plus to determine the performance of the alkaline electrolysis system under various operating conditions. The impact of the concentration of the electrolyte, pressure and temperature on the power consumption and efficiency of hydrogen production have been examined on the basis of the simulation results.

Figure 10. The correlation of concentration of potassium hydroxide (KOH) in mass percentage and the power requirement illustrates the correlation between the concentration of potassium hydroxide and the power requirement. The results indicate that the more the KOH concentration, the lower the amount of electricity required to generate hydrogen. The concentration of ionic electrolytes increases ionic conductivity that decreases the internal resistance within the electrolysis cell and, therefore, decreases the energy use.

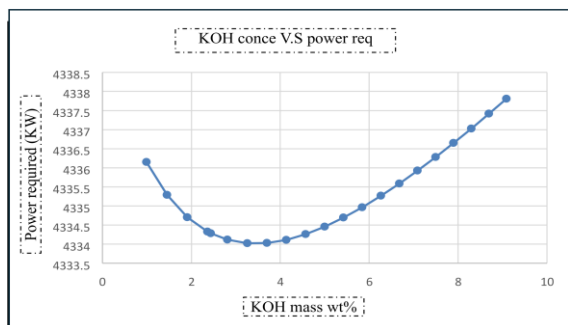

Figure (10): The relationship between the concentration of potassium hydroxide (KOH) by mass percentage and the corresponding power requirement.

Figure 11 Relationship between Temperature of feed stream with power required. The figure below demonstrates how the temperature of the feed stream influences the power demand.

The simulation outcomes prove the fact that there is a significant reduction in the required power when the temperature rises between 10°C and 90°C, and the decrease is approximately 80 kW. High temperature enhances the rate of reaction, ionic mobility of the solution, reduces the quantity of energy required to activate reactions as well as the overall effectiveness of the electrolysis system.

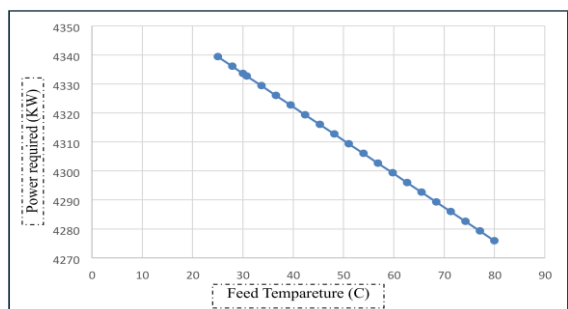

Figure (11): the relationship between of Temperature of feed stream with power required.

The simulation analysis revealed that the highest cause of the voltage losses in the electrolysis system is the activation overpotential. The kinetic constraints of the electrochemical reactions on the electrode surfaces are identified as activation overpotential and this plays a major role in determining the energy efficiency of hydrogen production systems. That is why optimization of electrode materials and operating conditions can have a significant contribution to the elimination of energy losses and enhancement of the work of electrolyzers.

Discussion

With the help of the experiment and simulation, it is continually observed that alkaline water electrolysis (AWE) with potassium hydroxide (KOH) used as the electrolyte is more efficient in the generation of green hydrogen than when sodium hydroxide (NaOH) is used as the electrolyte. This advantage can be heavily attributed to the fact that at given concentrations in solution, ionic conductivity of KOH is higher, which can be explained by the smaller hydration radius and higher mobility of K ions

compared to Na ions, faster ion conductivity and reduced resistance to the solution (American Chemical Society, 2023; International Energy Agency [IEA], 2022; U.S. Department of Energy [DOE], 2022). Accordingly, when using KOH solutions, overpotentials are reduced and hydrogen yields increase throughout a large span in applied currents and voltages. In fact, as an illustration, in identical conditions of operation, considerably more hydrogen was collected using KOH as compared to NaOH. NaOH on the other hand showed decreasing returns beyond a solution strength of about 15 g/L and this may happen due to saturation effects and reduced conductivity of NaOH towards stronger concentrations (Hydrogen Council, n.d.). The influence of the pressure on the overall efficiency of the system is also good though not as much as the one it exerts on the decreasing of the bubble effects of gases on the surfaces of the electrodes. The small minimized bubble size is assisted by the increased pressure, the bubble separation is boosted, and the coverage of the bubbles is minimized, which leads to the reduced ohmic resistance of a gas void fraction on the electrolyte. Such suppression of bubbles has a minor impact on the reduction in specific energy consumption and is in line with the literature on enhanced bubble kinetics under moderate pressurized conditions (DOE, 2022; IEA, 2022). Still, the pressure drops should be moderate as the pressure difference between half-cells might lead to an increase in the intensity of the diffusion and convection of gases and, consequently, a reduction in the purity of hydrogen and a threat of safety hazards because of the possibility of the existence of explosive mixtures of hydrogen /oxygen. As the simulation outcomes indicate, it will not be necessary to be purer than 99 percent of moderate-level system pressure of about 12 bar and additional separation or recombination may be necessary (DOE, 2022; International Renewable Energy Agency [IRENA], n. d.). The activation overpotential was also discovered to cause voltage loss in the experimental AWE system especially in the low to moderate current densities. This impact is correspondingly related to the kinetic restrictions of the hydrogen evolution reaction (HER) and oxygen evolution reaction (OER) on non-precious electrodes. The electrode surface charge transfer barriers observed give rise to activation overpotential and are exaggerated due to gases in the presence of blocked active sites. KOH concentrations of 2025 wt.%, an increase in the feed temperature (up to 90°C), and moderate pressure that can contribute to the optimization of the reaction kinetics, mass transport, and the residence behavior of the bubbles are such strategies (DOE, 2022; IEA, 2022). The overall response of the experimental results was similar to that of the Aspen Plus simulation models with variation of up to 6 percent in both power consumption and efficiency. This is to the credit of the thermodynamic and electrochemical assumptions made in the model. Overall, these findings confirm how good KOH is in AWE and highlight how alkaline electrolysis systems can be promising to supplement the intermittent renewable energy sources, such as solar and wind to generate low-carbon hydrogen and reduce greenhouse gas emissions in

the energy and petrochemical sectors (IEA, 2022; IRENA, n.d.; U.S. Department of Energy, n.d)

CONCLUSION

This paper has demonstrated that the optimum performances of the alkaline water electrolysis which involves the use of KOH with the concentration of 20-25 wt/l, high operating temperature (up to 90 °C), moderate operating pressure (up to around 12 bar) and techniques of minimizing the activation overpotentials yield a high overall efficiency (65) and a higher rate of hydrogen generation than the approach which KOH has been strongly proposed to be the option of all superior electrolytes on the basis of its high ionic conductivity, reduced saturation limits and enhanced response to parametric changes.

The results confirm the combination of experimental results with Aspen plus simulation of predictive optimization, which provides a solid foundation to enlarge green hydrogen production with less energy usage and environmental impact. It is recommended that future research should pay more attention to the long-term stability of electrodes under the pressurized conditions, better approaches to the bubble control (e.g., pressure oscillations or modified electrodes) and full decarbonization of the system in connection with the renewable energy sources to be further increased in the economic feasibility and support the global decarbonization agenda.

REFERENCES

- Abdel Rahman, I. A. F. (2008). General and physical chemistry. Dar Al Nahda Al Arabiya.
- American Chemical Society. (2023). Hydrogen chemistry.
- American Chemical Society. (n.d.). American Chemical Society.
- American Society of Mechanical Engineers. (2017). Handbook of pumps and pumping: Pumping manual international.
- Boyd, P. (2014, July 19). What is the chemical composition of stars? NASA.
- Elsevier. (2023). Hydrogen reactions. ScienceDirect. Encyclopaedia Britannica. (n.d.). Hydrogen. Encyclopaedia Britannica.
- Gad, M. A. M. (2009). General chemistry. Dar Al Nahda Al Arabiya.
- (already includes DOI) Khan, M. Z., Nizami, A. S., Rehan, M., Ouda, O. K. M., Sultana, S., Ismail, I. M., & Shahzad, K. (2017). Microbial electrolysis cells for hydrogen production and urban wastewater treatment: A case study of Saudi Arabia. *Applied Energy*, 185, 410–420. <https://doi.org/10.1016/j.apenergy.2016.11.005>
- Hydrogen Council. (n.d.). Hydrogen Council.
- International Energy Agency. (2022). Hydrogen: A renewable energy perspective. IEA.
- International Renewable Energy Agency. (n.d.). International Renewable Energy Agency.
- LibreTexts. (2023). Chemical properties of hydrogen. Chemistry LibreTexts.
- Liu, Y., Zhang, Y., & Zhang, Z. (2022). A review of hydrogen production by methane reforming. *Renewable and Sustainable Energy Reviews*, <https://doi.org/10.1016/j.rser.2023.110889>
- Mitsidi. (n.d.). O que você precisa saber sobre. National Institute of Standards and Technology. (n.d.). National Institute of Standards and Technology.
- National Renewable Energy Laboratory. (2022). Hydrogen production technologies.
- Neckers, D. C. (2003). Photoinitiators: Structures, reactivity and applications in polymer chemistry.
- U.S. Department of Energy. (2022). Hydrogen production. U.S. Department of Energy.
- U.S. Department of Energy. (n.d.). Hydrogen production: Electrolysis. U.S. Department of Energy.
- U.S. Department of Energy. (n.d.). U.S. Department of Energy.
- United States Environmental Protection Agency. (2015). Low emission boiler system proof of concept project: Environmental impact statement. University of California. (n.d.). University of California.
- Walter, H.-U. G. (2008). Handbook of valves and actuators: Valves manual international.